

**HD-5C GRINDER W/ HANDFEED HOPPER,
AIR SEPARATOR, & DB-5 BLOWER
(REF W-7305-311)**

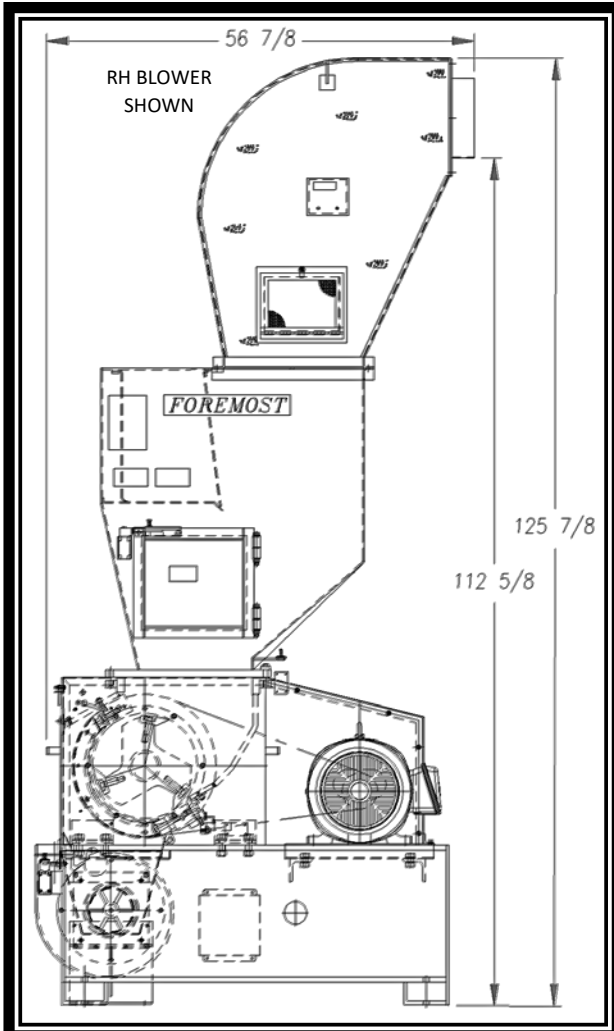

*LH / RH BLOWER ORIENTATION TAKEN FROM PERSPECTIVE
WHEN FACING MOTOR

APPLICATION:

- BLOW MOLDING TRIM & START UP SCRAP
- THRU PUT APPROX. 750 LBS/HR
- 16" X 20" THROAT OPENING TO ACCOMMODATE LARGE UNTRIMMED CONTAINERS
- CONSULT FACTORY FOR SPECIFIC APPLICATIONS

FEATURES:

- HIGH SHEAR KNIVES TO MINIMIZE FINES & DUST FOR PE AND PP APPLICATIONS
- OFFSET ROTOR DESIGN TO MINIMIZE FLYBACK
- HEAVY DUTY SELF ALIGNING ROLLER BEARINGS

SPECIFICATIONS:

FEED:	TANGENTIAL
HOPPER:	HAND FEED
THROAT:	16" X 20"
ROTOR SHAFT SIZE:	3-1/2"
ROTOR:	THREE BLADED, STRAIGHT RIBBED, SINGLE DRIVEN
ROTOR SPEED:	438 RPM
KNIVES:	THREE 18" ROTARY HI-SHEAR TWO 20" BED
CUTTING DIAMETER:	14"
FLYWHEEL DIAMETER:	16"
SCREEN:	Ø3/8", 52% OPEN - STANDARD Ø5/16", 36% OPEN - OPTIONAL
POWER:	30 HP 1800 RPM TEFC MOTOR
ELECTRICS:	460V, 3 PHASE, 60 CYCLE (STANDARD)
SAFETY SWITCHES:	WIRED TO PREVENT OPERATION OF GRINDER WHEN HOPPER IS OPEN OR IF SCREEN IS EXPOSED
CONTROLS (UL LISTED):	NEMA 12 PANEL (UNMOUNTED) W/FUSED DISCONNECT & INTERLOCKED STARTER FOR GRINDER & OPTIONAL BLOWER MOTOR. CONTROL VOLTAGE 120V

9/27/2018



REQUIRED OPTION:

- **HANDFEED HOPPER: (W-7305-85)**
Heavy duty 7 ga. Hopper features are robust mounting flange, steel framed cleanout door with safety switch and curtain to prevent material flyback.
- **DAIRY HOPPER II: (W-7305-219-1)**
Full throat discharge hopper, circular split hopper, access door, dual baffles, constructed of heavy duty sheet and flattened expanded metal. (2) 10" inlets standard.
- **CONVEYOR HOPPER: (W-7305-132)**
Heavy gauge alloy steel, welded construction. Hopper features are robust mounting flange, steel framed cleanout door with safety switch, and vinyl curtain to prevent material kick back. This hopper has an angled conveyor shelf for mounting a feed conveyor to the grinder.
- **AIR SEPARATOR: (W-5007-107)**
Select inlet from next page. Heavy duty perforated steel hopper with inlet mounting plate and cleanout doors. Must be mounted to the hand feed hopper or the air separator extension. Standard is (2) 10" square.
- **AIR SEPARATOR EXTENSION: (W-SK-7305-117)**
Heavy duty 7 ga. Hopper features are robust mounting flange, steel framed cleanout door with safety switch. Baffle to prevent material flyback.

OPTIONAL:

- **MATERIAL INFEEED ALARM:**
Photo-Eye sensor, with remote alarm panel to indicate material buildup at grinder hopper.
- **CASTERS:**
4 Heavy Duty (2 Swivel and 2 Fixed)
- **REVERSE STANDARD MOUNTING:**
Blower chute and the clean out doors to be mounted on the reverse sides of the machine.
- **QUIET MODEL AHD-5C GRANULATOR, WITH SOUND ATTENUATION**
- **MODEL DB-5 BLOWER:**
Complete with a 5HP motor, magnetic starter.
- **MODEL 750 CYCLONE:**
For regrind discharge. Other sizes are available.
- **ELECTRICS:**
230V, 3 Phase, 60 Cycle



OPTIONAL (CONT):

- ADAPTORS:
Extensions available to change height of grinder.
- PANEL MOUNT:
Talk to a sales representative about ways to mount the control panel on or around the grinder.
- INFEED BELT CONVEYOR:
Different arrangements available.
- DUAL SET POINT AMMETER:
To regulate infeed conveyor.
- AIR SEPARATOR HOPPER INLET
The air separator hopper is available with multiple inlet arrangements as listed below.

# of Inlets	NONE	1	2	3	4	1	1
Size	Blank Plate	10" Square	10" Square	10" Square	10" Square	12" Square	12" Square RH
# of Inlets	1+2	3	1	1	2	1	1
Size	(1) 12" Square & (2) 10" Square	12" Square	10" Outer Dia.	11" Outer Dia.	11 ½ Inner Dia.	12" Outer Dia.	14" Outer Dia.

* Other configurations available. Please consult with Foremost for pricing.

Paint: Equipment is painted Foremost White.

Electrical enclosures are powder coated by the manufacturers and not repainted prior to shipment. They can be grey or black depending on manufacturer.

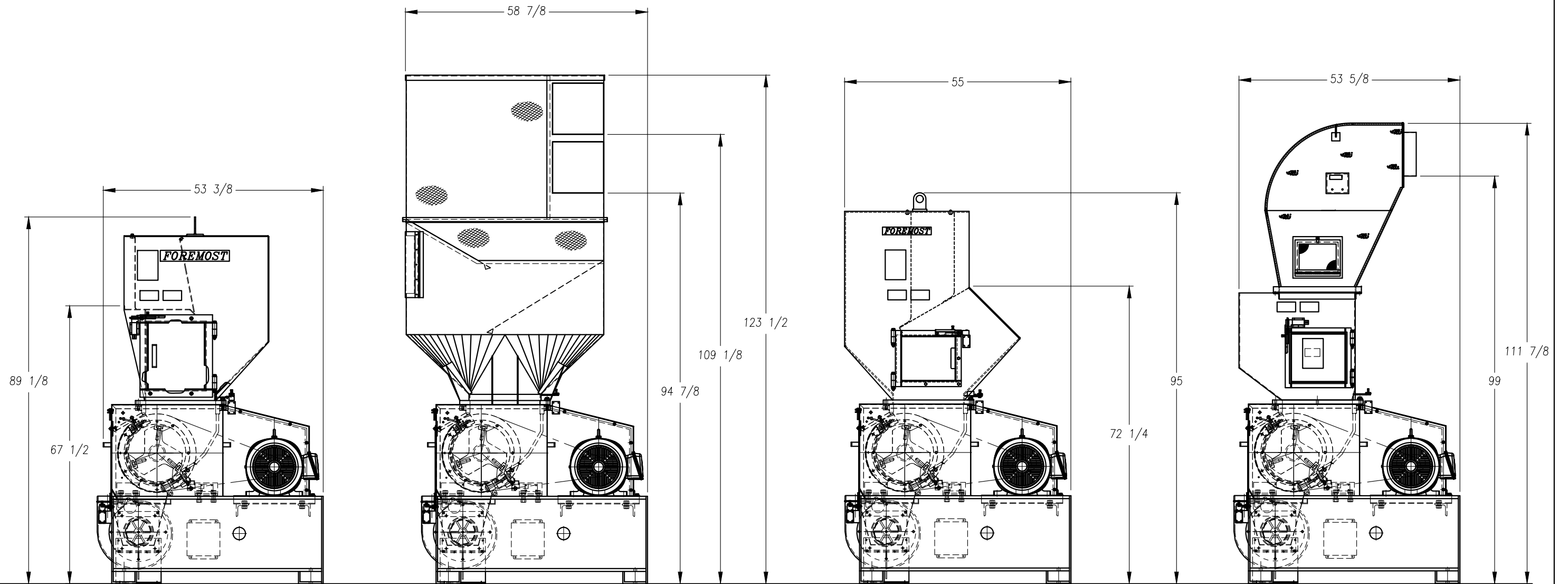

HD-5C GRINDER,
W/ HANDFEED HOPPER & DB-5 BLOWER
(REF W-7305-281)

HD-5C GRINDER,
W/ DAIRY CYCLONE, DB-5 BLOWER
& (2) 12" SQ. INLETS
(REF W-7305-271)

HD-5C GRINDER
W/ CONVEYOR HOPPER & DB-5 BLOWER
(REF W-7305-253)

HD-5C GRINDER,
W/ EXTENSION, AIR SEP. & DB-5 BLOWER
(REF W-7305-303)

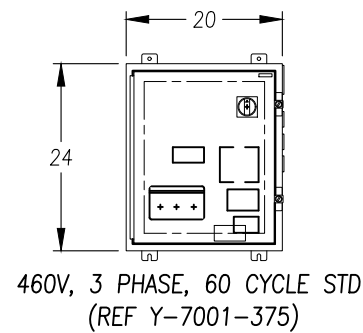

THIS DRAWING IS THE PROPERTY OF FOREMOST MACHINE BUILDER, FAIRFIELD NEW JERSEY, U.S.A. IT SHALL NOT BE REPRODUCED, COPIED, LOANED OR OTHERWISE DISPOSED OF DIRECTLY OR INDIRECTLY. IT SHALL BE USED AS A MEANS OF REFERENCE TO WORK PROPOSED BY THIS COMPANY ONLY AND IS NOT TO BE SUBMITTED TO OUTSIDE PARTIES FOR EXAMINATION WITHOUT OUR CONSENT. ALL RIGHTS OF DESIGN AND INVENTION ARE RESERVED.

JOB NO. _____
QUANTITY: _____

FRACTION ±1/16
2 DEC. PL. ±0.010
3 DEC. PL. ±0.005
MM ±0.5
ANGULAR ±0°-30'

STANDARD TOLERANCES UNLESS OTHERWISE SPECIFY

HEAT TREAT: SPEC.

SURF ROUGH 250 ✓

FOREMOST
MACHINE BUILDERS INC.
WWW.FOREMOSTMACHINE.COM

APPLICATION		DRWN	DATE	TITLE	
ALL DIMENSIONS ARE IN INCHES EXCEPT AS NOTED		MS	9/21/18	HD-5C W/OPTIONS	
STANDARD TOLERANCES UNLESS OTHERWISE SPECIFY		CHKD	DATE	SHOWING STANDARD ARRANGEMENTS	
HEAT TREAT: SPEC.		APPD	DATE	SCALE	DWG NO
SURF ROUGH 250 ✓				1/24	Y
				SH 1 OF 1	REV